

## GPRS network used to monitor the generation and use of solar energy in residences

Robson da Cunha Santos<sup>(a,b)</sup>, Gerson Gomes da Cunha<sup>(c)</sup>, Marcos Antônio Cruz Moreira<sup>(a)</sup>, Mônica Castelo Branco<sup>(b)</sup>, David Douglas Nunes Oliveira<sup>(a)</sup>, Matheus Muzitano Reis<sup>(a)</sup>

<sup>(a)</sup>Fluminense Federal Institute, Campus Macaé, Automation and Control Engineering  
164 km Amaral Peixoto Road, Brazil

<sup>(b)</sup>Estácio de Sá University, General Alfredo Bruno Gomes Martins Highway, s/n -Braga  
- Cabo Frio / RJ, Brazil

<sup>(c)</sup>Federal University of Rio de Janeiro, Alberto Luiz Coimbra Institute Graduate  
Engineering and Research, Civil Engineering Program/COPPE/UFRJ

<sup>(a)</sup>[profrobsons@yahoo.com.br](mailto:profrobsons@yahoo.com.br), <sup>(b)</sup>[gerson@lamce.ufrj.br](mailto:gerson@lamce.ufrj.br), <sup>(c)</sup>[macruz@iff.edu.br](mailto:macruz@iff.edu.br),

<sup>(d)</sup>[xxmoninfante@yahoo.com.br](mailto:xxmoninfante@yahoo.com.br)

<sup>(e)</sup>[daviddouglas@gmail.com](mailto:daviddouglas@gmail.com), <sup>(f)</sup>[fenmattcf@hotmail.com](mailto:fenmattcf@hotmail.com)

### ABSTRACT

The article describes a system for solar power generation, integrated into a "grid-tie" inverter, converting Direct Current "DC", generated by the plates in Alternating Current "AC" on the standards of electrical distribution network. The energy generated is quantified by smart metering module that transmits the information in specified periods of time to a microcontroller via GSM modem. The modem provides the measured data on the internet, using networks and cellular antennas. The monitoring, fault detection and maintenance are performed by a supervisory station. Employed board types, best inverter selection and studies about control equipment and devices have been described. The article covers and explores the global trend of implementing smart distribution electrical energy networks and the incentive to use solar renewable energy. There is the possibility of the excess energy produced by the system be purchased by the local power utility.

Keywords: Smart Grid, Microcontroller, Supervisory, Solar Energy, GSM.

### 1. INTRODUCTION

The concessionaires of electricity distribution provide their customers a fully manual system that does not offer the customer control of its consumption, nor is there an opportunity of interacting with the current system. Cited by many researchers and checked in CRESEB (Reference Center for Solar Energy and Wind Sérgio Salvo de Brito) site, one observes that solar power has not yet reached a level of economic competitiveness with conventional energy sources, due to a number of factors, including lack of incentives (tax reduction) and low efficiency of solar panels marketed today (Pinho, 2014). Despite these factors, one cannot

consider using these panels merely as an alternative energy source, but also as a technically feasible option. For it is possible to have a return on investment in the long term by reducing pollution through the steep fall in emissions carbon and eliminating the need of flooding deforestation of large areas such as the hydro entails.

The research is justified for developing an automated system, which enables the consumer no longer being just a passive agent of the generation and transmission of electric power business, bringing the possibility of him/her being in charge of its central micro generator installed at his residence.

Installing a variable frequency drive connected to the power grid causes the consumer to make available all mains power generated during the day. This energy is born by the concessionaire for distribution to other consumers and overnight the consumer - that generated energy during the day - shall take back the energy he generated during the day. The energy meters installed in rural homes works amounting consumption or regressing consumption if the unit is power generating.

At the end of the month the negative (energy generated greater than consumed) or positive (energy consumed greater than that generated) balance occurs. To current Brazilian legislation, in case of negative balance, nothing will be paid by the consumer, but it is now under study for some years adjusting the law so that the consumer can receive for its energy generated more than consumed.

The installation of the new Grid Tie inverter technology eliminates the need for installing batteries, which have a high cost and a low life (about five years). In older versions of solar panels installing the battery bank accounted for nearly fifty percent of the total investment. Regarding modern data acquisition systems, portability and mobility are essential for most applications. In this sense, it has become essential to

add internet connection to the new and modern data acquisition systems. In view of this new perspective, this paper proposes an acquisition data system based on cutting-edge and innovative technology inside current marketplace. This includes data capture using microcontroller and data transmission via cellular, specifically using the GPRS / Internet technology. These data are checked from a supervisory system and this enables making decisions for the case of low efficiency of the system and to check for fraud or intervention required for maintenance.

## 2. DESIGN PARTS

Power generation through solar panels is somewhat already well consolidated around the world. However, there is still much room for modernization of systems, as more modern ones are created, and use becomes increasingly common due to the continuous increase in system efficiency.

### 2.1 Solar panels

The solar panel can be defined as a device designed to convert solar radiation into energy. For relying solely on the sun, the most abundant energy source on the planet, it is the cleanest method known of power generation (Sukhatme, 2008). The Photovoltaic Solar Panels are associations of photovoltaic cells that convert sunlight into electricity. Most of these solar cells are made of silicon or gallium arsenide, and present dark color, for greater capture of light energy. The silicon solar cells produce less energy compared to gallium, but their cost is proportionately lower.



Figure 1: Solar Panels (Pinho,2004)

In the previous figure are shown two examples of solar panels, the difference between them is visible once the left figure, it is polycrystalline panel and the right figure is in a monocrystalline panel, the difference is in the manufacturing process (Pinho, 2014).

### 2.2 Inversor Grid Tie

Before the development of Grid Tie Inverters (grid connected) there were only standalone inverters (Off-Grid Inverter) that are not connected to the power grid and were designed to create an AC voltage from DC power stored in batteries. The later ones are used in autonomous systems such as detached houses, boats, and UPS systems (emergency power supply). These devices are not simultaneously connected to the mains power supply grid. As seen in the following figure, one

notices that the load has no connection to the power network; its energy demand is supplied exclusively by the battery.

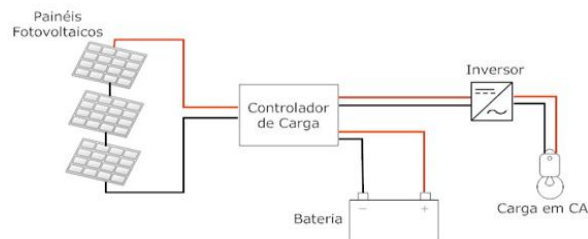

Figure 2: Stand-alone photovoltaic system (the author)

The grid-injection inverters (Grid Tie Inverter) create an AC voltage directly from the Photovoltaic panels; without using batteries. They inject energy into the grid, thus allowing trading of electricity. The main difference between a conventional inverter (Off-Grid inverter) and Grid-Tie inverter is that the latter is able to interconnect with the network utility, due to its ability to synchronize its frequency and its output voltage to the network in which to connect. They are also able to break away from the utility grid when it does not supply power. The panels can be connected directly to the inverter. There is no spending on batteries and charge controllers.

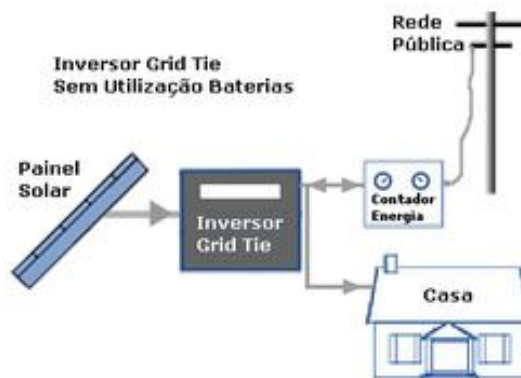

Figure 3: Grid Tie Inverter Connection (the author)

### 2.3 Smart Meter

The meter from manufacturer Elster A102C model displayed in the following figure provides an economical solution for domestic applications. The meter provides a communication port IRDA (Infra Red Data Acquisition), optical output for reading different information on the meter operation. In the liquid crystal display one may view the total energy measured in kWh.

This can be configured for single-phase measurement of direct or direct/reverse energy both for residential and small commercial / industrial users. Furthermore, it provides the measure of active and reactive power. The meter has an output that can provide signals for power controllers, demand controllers or remote reading systems.

The meter from manufacturer Elster A102C model displayed in the following figure provides an economical solution for domestic applications.



Figure 4: Elster A102C meter (Elster,2012)

### 2.4 Plataforma Arduino

The Arduino project was created in Italy in 2005 with the goal of providing a low cost, easy using platform for electronics prototyping, to be used by anyone interested in creating interactive devices with objects and their environment. (Banzi,2011).

The Arduino electronics board contains multiple inputs and outputs, analog and digital, and serial interface via USB connection to communicate with the computer. The smart card is an element of the AVR microcontroller family that allows thousands recordings and rewrites in its program memory.

In order to increase the functionality of the Arduino board, several companies have developed hardware for connecting additional electronic boards on the Arduino terminal. These additional electronic boards are called "Shields" and add various functions specific to the Arduino. In this article will be described the GSM Shield.

The Arduino Mega 2560, displayed in the following figure, is a microcontroller board based on the ATmega2560 microcontroller. It has 54 pins for digital inputs / outputs, 16 analog inputs, 4 UARTs (hardware serial ports), a crystal oscillator of 16 MHz , a USB connection, an input power, an ICSP connection and a reset button.



Figure 5: Arduino Mega2560 (Banzi,2012)

### 2.5 GSM Shield

The card with GSM module SIM900 displayed in figure 6 is a board that can be easily attached on the

Mega2560 Arduino board, extending the functionality of the GSM module to the resulting assembly. This board is stacked on the Arduino board, through all its pins. The GSM module SIM900 board uses this structure to its power feeding and functioning. (Banzi, 2012).

The SIM900 GSM module, produced by SIM Com, is responsible for communication with the GSM network making possible the effecting and receiving phone calls and text messages.

The modem is a device for wireless communication. This equipment enters a new trend of technology known as M2M (Machine to Machine) in which this project is based.

GSM modems can operate even in voice mode, but their greatest uses are for data transmission that occurs through three types of technology: CSD Connection (Circuit Switch Data); GPRS Connection (General Packet Radio System) and SMS (Short Message Service).



Figure 6: SIM900 GSM/GPRS (IteadStudio, 2012)

### 2.6 Supervisory and Data Acquisition System

The supervisory and data acquisition systems (SCADA) were created due to the need for an interface that was operator friendly to plant control. Are also known as Human Machine Interface (HMI) or 'Supervisory' only.

The main objective of the Supervisory system is to provide a simple way to monitor, control and manage multiple points of an automated plant. The data that will be processed by the SCADA can be obtained through a connection with a controlling element, equipped with sensors or even the data is entered directly by the operator.

## 3. ASPECTS OF INTERNET-INTEGRATED WIRELESS COMMUNICATION

Since the creation of the telegraph, through the creation of radio communication, reaching the creation of the phone until the creation of the cell phone, much has evolved in terms of point to point communication. However, the major event of the last century was the development of wireless and mobile communication,

like the cell phone. From this, it comes the need and wish to improve the cell phone. The GSM network which was created and later enhanced to data communication, as previously it was possible only voice communication.

### 3.1 Historical of GSM Technology

The data transmission via mobile phone has become an innovative solution for the incorporation of new values in technology, which allows to add a quality hitherto existing services in fixed-line telephony service with the mobility factor, the main distinguishing point in cellular telephony. Added to this, there is now a full integration between the mobile phone and the Web network, which forms a vast technological potential application (Wirelessbrasil, 2012).

### 3.2 GSM Network Operation

According to the schematic of Figure 7, the mobile stations (MS), that may be mobile (and portable) phones or mobile units installed in cars, talk with the Base Station System (BSS) through the air interface of Radio Frequency (RF). The Base Station System (BSS) consists of a Base Transceiver Station (BTS) and Base Station Controller (BSC). It is common for several BTS be located in one same location, creating two to four sectored cells surrounding a common antenna tower.

The BSC are often linked to the BTS by microwave links. The link to the BTS BSC is called the Abis interface. Typically, 20 to 30 BTS are controlled by a BSC. In turn, several BSS are subject to a Central Switch and Control (MSC), which controls the traffic between several different cells. Each Central Switching and Control (MSC) will have a Visitor Location Register (VLR) in which the mobile units that are out of the cells of their local area will be listed, so that the network knows where to find them. The MSC is also connected to the Location Register of Local Mobile Unit (HLR), the Authentication Center (AUC) and the Equipment Identity Register (EIR), so that the system can verify that users are subscribers and equipment legal situation. This helps preventing the use of fraudulent or stolen mobile units. There are also facilities within the system to the Operations and Maintenance Organizations and Network Management (NMC).

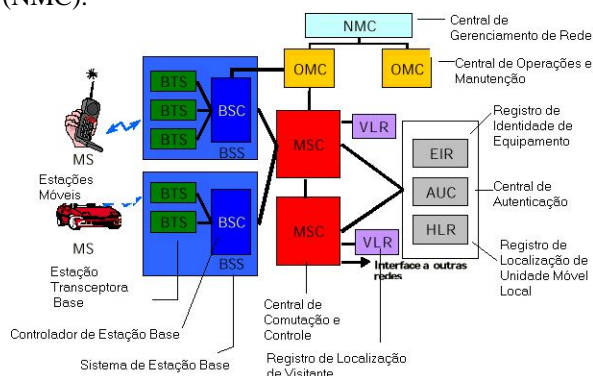

Figure 7: GSM Network Frame (Wirelessbrasil, 2012)

## 4. SOLAR ENERGY AS A SOURCE OF ELECTRICITY

Solar energy as an energy source will not have the ability to substitute other energy sources used today because its generation is seasonal not allowing a continuous feed of large systems. However, its popularity, with the implementation of new systems around the world, will make it complement other sources of generation, thus reducing the environmental impact generated by other energy sources

### 4.1 Historical of Photovoltaic Solar Energy

As a definition, solar photovoltaic energy is the energy coming from the direct conversion of light into electrical energy. In 1839, this phenomenon was first described by French physicist Edmond Becquerel, when reporting the properties of selenium, which produced an electrical current directly proportional to the incident radiation.

The subject began to receive a great attention from the '60s, during the Cold War, as, despite its high cost, this technology proved suitable to meet the energy demands in aerospace missions as well as for supplying satellites. Government programs in countries like Germany, Spain and Japan stimulated domestic application of this technology, which allowed for a production scale, further reducing costs.

Nowadays photovoltaic cells are quite popular, produced with thin films. They use even less material and energy in their manufacturing process than the polycrystalline silicon, which justifies its price more affordable (Serrão, 2010).

### 4.2 Environmental Impacts

It can be said that the environmental impact is one of the most relevant points as it comes to solar energy. The most significant environmental impacts occur at the production, construction and decommissioning of photovoltaic cells.

In constructing these plates, various types of environmental and health hazardous materials are used, besides being consumed a large amount of energy, which is related to the emission of air pollutants such as greenhouse gases. Compared with a conventional thermal power plant, solar power generation emits 20% less CO<sub>2</sub> for the same amount of energy produced (Naturlink, 2012).

### 4.3 Current Feasibility in Brazil

According to a study conducted by the Energy Research Company (EPE), residential solar power production is now economically viable for 15% of Brazilian households.

Under the new resolutions of the National Electric Energy Agency (ANEEL), published in 2012, customers who possess solar panels in their homes can not only reduce the consumption of electricity purchased from concessionaire but also generate credits for use in other months.

Under this system, the generating unit installed in a residence, for example, will produce power and what is not consumed will be injected into the distribution system, which uses the credit to subdue the consumption of subsequent months. The credits can be used for a period of 36 months and information will be provided for the consumer, so that one knows the balance of power and have control over his invoice.

In 2012 there were only eight projects of this type and some residences distributed, generating approximately 15MW of a total of 430,000 MW consumed by Brazil (BRAZIL, 2012).

The country has the option of waiting for the cost of solar power to decline to put it on auctions or to create a specific auction so there is no dispute with other cheaper sources such as wind. But that would be sold a small amount of energy not to burden the consumer (Tolmasquim, 2012)

## 5. SISTEM DESIGN

System integration was the most laborious part of the project, due to the high level of detail required for its integration. It required a high volume of surveys of sites of companies and components manufacturers.

### 5.1 Motivation

Initially, the goal was to create a monitoring system for some kind of alternative energy, to be deployed by a company that would provide installation and maintenance of equipment used in the generation of a residential customer.

The methods to achieve these results were studied and analyzed to choose the technologies which fitted best the goal. The decisions were taken at the beginning involved the following circumstances:

- Renewable Energy Generation Method: Solar or Wind Power.
- Harnessing System: Battery bank, Direct Grid Injection or Hybrid System.
- Measurement of Power Generated: Conventional Electronic Meter or Analog Voltage and Current Readers.
- Process Controller: PIC, PLC or Arduino.
- Monitoring System Communication Interface: Wi-fi, GPRS or SMS.
- Monitoring System: Webserver, Elipse ou Intouch.

### 5.2 Research and Choices

The initial stages of project development involved long research time and studies for decision making. The primary research methodology was accessing several sites on the subject, in addition to performing some technical visits, which had great influence in the paths to be followed in the project.

### 5.2.1 Renewable Energy Generation Option

To decide which method of power generation would be used, several studies were conducted to understand the advantages and disadvantages of each alternative energy source.

The price for wind power generation is significantly cheaper than the solar power generation although the techniques for wind energy are well developed and should not evolve much in the short term.

Solar power is still quite expensive to be produced, but the growing trend in production technologies is that due to government incentives these energy prices will fall enough and should equal the wind energy prices shortly. This point has greatly influenced the choice as one of the goals was to have a vision of the future solar power market and proved to be the wisest choice.

Another point that influenced the choice of solar energy was that the blades of the wind turbine have an impact on the local birds, especially due to the shock of these birds in blades and unknown effects on modifying their usual migration behaviors. Furthermore the noise impact caused by wind power generators that may reach a constant noise up to 43 dB, which can disturb the inhabitants of the residence up to 300m distances.

Then photovoltaic panels were chosen to generate alternative energy, harnessing solar energy. Two modules KD54 plates of 50Watts each were acquired from Kyocera, the most trusted brand and market leader in Brazil.

### 5.2.2 Harnessing System

At first the idea was to mount a hybrid system to harness the energy generated. Throughout the research it was noticed that there was no a need to use a battery bank, except in cases where there is no electricity grid next the residence. In the Lakes Region, location of the tests, almost all residences have access to the electricity grid, confirming the dispensability of a system with battery bank. Thus, all the energy generated by the system will be injected directly into the grid of the power supply company (concessionaire) and slaughtered the amount that has consumed the dealership.

The equipment was chosen for this Inverter Grid Tie400W of GreenEnergyStart, which is a company focusing on alternative energy and use of current technologies.

### 5.2.3 Measurement of Energy Generated

At the beginning it was thought to use voltage and current readers in order to reach the energy generated because knowing the voltage and current power which is the product of these two quantities could be calculated.

The main methods found to construct a current player were the utilization of high power resistor and precision and very low resistance, which are known as shunt resistors and the utilization of Hall effect sensors,

which are analog signal proportional to the magnetic field created by a current that flows close to the sensor.

The solution was to acquire a meter certified by INMETRO, a trust company in the Brazilian market. Through contact with the supplier decided to buy an Electronic meter company Elster (A102C).

### 5.2.4 Process Controller

In any automated system, and monitoring, there is a necessity of a device that scan the sensors and treat the data according to the need.

One of the options for this type of process is the Programmable Logic Controller (PLC), but the factors that have eliminated the PLC project were its high cost and its high power consumption when in operation.

It was then decided by the use of a microcontroller, by owning a low cost and power consumption is extremely low.

The plate was chosen for the Arduino MEGA2560, which has more than 60 I / O and communication is based on an Atmel 2560 processor.

### 5.2.5 Means of Communication with the Monitoring System

Currently, there is a tendency in industries increasingly frequent use of wireless technologies for communication. Taking advantage of the growth of wireless networks, it was decided to this method to make communication between field elements and the monitoring system.

GSM networks are present in almost all places in Brazil, thanks to the "boom" of the cell and increased technical capacity of operators. In the Lakes Region almost everywhere already have access to this technology. So GSM networks has become a great option for use in this project, as it currently has lower costs for sending packets through GPRS connection and sending short messages (SMS).

For these purposes, was chosen GSM Shield V1.1 Icomsat company because its integration with Arduino is fast and easy, besides it be based on SIM900D which is a Quad Band GSM SIMCOM chip company.

### 5.2.6 Monitoring System

For the choice of supervisory system, two softwares, the Intouch and the Ellipse were considered and soon consolidated in the market to attend the need of the project.

The option was for the supervisory of the Ellipse, for being a Brazilian software and with an excellent technical support by phone, which could be useful, not to mention its lower price.

A Webserver is a complement to supervisory, because it can be accessed by mobile phones, tablets and other portable devices currently used.

The next step was the choice of communication protocol. Researching quite found out that the best solution was the Modbus TCP protocol, which is free from any type of recovery and is not complicated to use.

## 5.3 The Project Design

The project design was divided into parts, each part consisting of a different system design.

### 5.3.1 Mounting the System Generator

The project was started with the mounting of the solar power generation system. The first step was the determination of the best place for installation of solar panels. For added security, The location must be high, to prevent theft and animal access and should not be obstructions from sun rays (shade).

Then there was the determination of a position and an inclination to the plate, so that better take advantage of solar cycles. As the location of this project is the Southern Hemisphere, it is necessary to position the plate towards the north. To determine the ideal inclination, it is necessary to verify the latitude of the installation location and the approximate formula for calculating the inclination is that this should be 130% of latitude. In Rio de Janeiro, the approximate latitude of 23° is in this way allows an inclination of 30 ° on each plate.

The binding plates were performed in parallel, which gives a sum of currents of each plate, and maintains a voltage equal to a single plate. The following figure shows the installation and positioning of the plates.

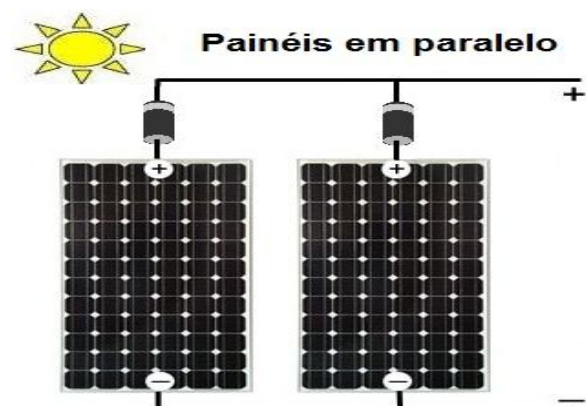

Figure 8: Panels in parallel (Mppsolar 2012)

After the connection of the plates, the connection of the Grid-tie was made. The positive output terminal of the plates was connected at the positive input of the CC inverter and also the negative output terminal was connected to the negative CC input inverter. Soon after, was connected to the AC output of the inverter in the network, by transforming all input power direct current into alternating current.

### 5.3.2 Installation of the Measuring System

With the generation system installed and working, the meter Elster A102C was installed between the inverter and the electric grid. The meter is installed in series with the inverter and the grid. The determined meter has 3 methods to inform the measured data. The output in standard IRDA, which works through infrared, pulse

output, is available through the auxiliary outputs, and an LCD display on the meter itself.

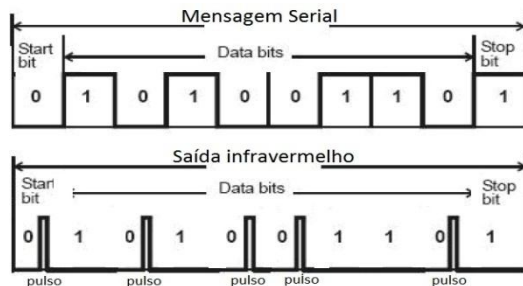

Figure 9: Padrão da Mensagem IRDA (Meterspec)

As the meter uses the LED emitting red light to send serial devices to reading information then was acquired a phototransistor infrared to decode the information in the standard meter IRDA. Each bit of zero value the meter wants to send, it sends a pulse of infrared LED emitter in Figure 9.

### 5.3.3 Controller

The monitoring system starts with the treatment of information measure and this function is realized by Arduino MEGA 2560.

The IRDA output was initially used to receive the data, but it was noticed that to be a serial message, the difficulty to decode the data would be much greater and more imprecise, since any loss of pulse would cause an incorrect reading. The pulse output of the meter was then used to obtain the required data.

Using a programming library that transforms the Arduino in a Modbus device. The pulse output is connected on the Arduino interrupt pin and when it detects a pulse signal, the Arduino registers and saves this information. Powering the Arduino is done by an external source or then connected directly at the output of the plate solar.

### 5.3.4 GSM communication

The Shield GSM has been connected in the Arduino board, as shown in Figure 10 and inserted a SIM card from a wireless carrier.

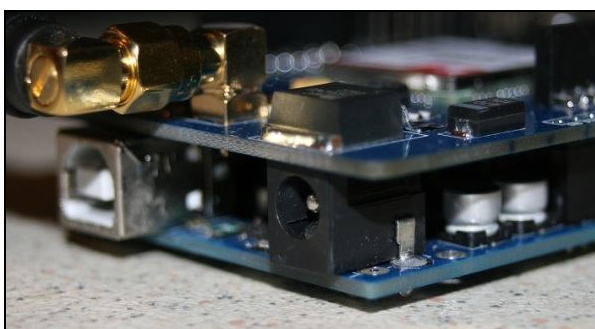

Figure 10: Mounting the GSM Shield with the Arduino (the author)

In programming, GSM is functioning as a transparent device, ie, it transmits any message that

arrives at your receptor. Programming the GSM plate is made by Arduino.

The function of GSM Shield is connect to the internet through GPRS and connect to a server through port 502, which is the default port for Modbus.

Then, when the Arduino sends a message to the GSM, it transmits directly to the IP defined through the door 502. This server is the supervisory station.

### 5.3.5 Supervisory station

In this step, the process of creating screens for user interface was started. There are two options for monitoring, one for the company that provides the system and one for the user who purchases the system.

Both are password protected and the user is only able to access the monitoring of your own residence. The company operator can access the monitoring of all installed points.

The first screen, known as the Home screen, displays the logo of the company supplying of the system described in this project, the version of supervisory and rights to creators, plus a welcome message and option to start the program. Clicking the named "About" button several information about the program, such as licenses and rights, information about the current version and contact is displayed, as shown in Figure 11.

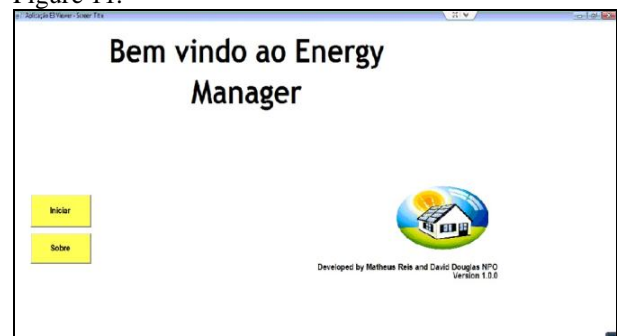

Figure 11: Home screen the supervisory (the author)

In the version of the user, after the program is started, a screen is displayed for this user in case there is more than one installation point for him, so that he can select the point that he wants to see, that is to say, the information of the installed system.

In the version of the operator, a screen is displayed where you can choose, with one click, the city to be monitored. After it is performed by the operator, he selects the point at that he wants to view the data received by the generation system of the selected location. If any the system is producing below the normal standard, the place is displayed with a yellow circle. If the system is not producing, a red circle is displayed, as shown in Figure 12.

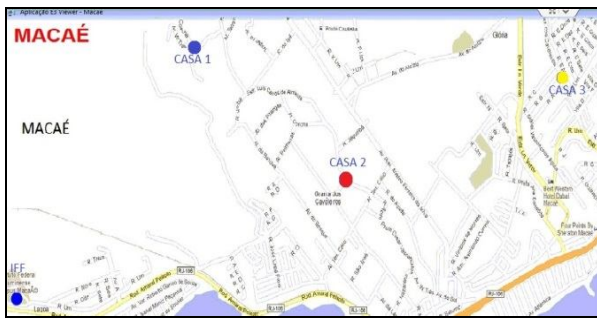

Figure 12: Map of the city of Macaé in the highlighted points (the author)

In Figure 13, it may be perceived a common screen to the user and the operator. It shows the data processed by the Arduino, as the quantity of energy generated at the moment and in the last 12 hours.

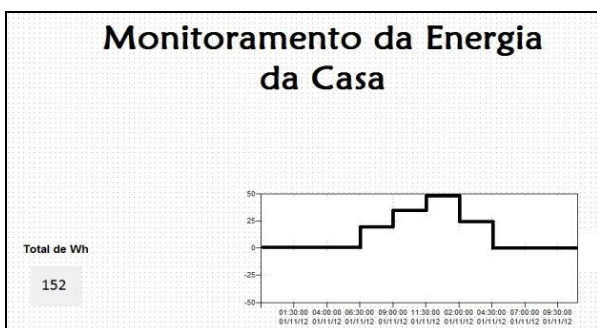

Figure 13: Screen Supervisory Control (the author)

The communication driver that was used in the supervisory is Modbus and was configured with parameters of identification of Arduino. A tag communication was created to store the information obtained by Arduino through register read function. The Ellipse performs in the range of 1 minute, reading the register that stores the information from the meter and displays on screens previously determined. The history is done by storing in a internal database values and the tag after displaying the chart.

A low alarm value has been placed in this tag communication and time associated with a solar shift, ie, in a time of solar generation a certain house is not generating a signal is displayed on the selection screen of points to be monitored and because there is a problem with the system and if the alarm persists a technical should go to the local to do the verification.

## 6. RESULTS OBTAINED

After adjustment of the positioning experiments the plates were made for sampling results on the relevance of the project. Sampling and analyzing the total energy generated per day in the second fortnight of November 2012, there was obtained an average of 240Wh per day for each plate of 50W of power, as shown in Table 1.

Each plate 50W Kyocera, used in the project, costing on average R\$500.00 and each inverter 400W

R\$600.00 costs on average and supports up to 8 plates 50W.

Table 1: Total generation Nov./2012 second fortnight

Month of November 2012		
PLATE OF 50W - KYOCERA		
Day	Total of Generation (Wh)	Condition of the Day
16	212	Cloudy
17	281	Sun
18	231	Sun / Cloudy
19	241	Sun / Cloudy
20	175	Cloudy
21	149	Cloudy
22	206	Cloudy
23	275	Sun
24	270	Sun
25	260	Sun
26	216	Sun / Cloudy
27	225	Sun / Cloudy
28	303	Sun
29	301	Sun
30	256	Sun
Total	3601	
Average	240,07	

The tariff of local dealership in the region is 0.66 R\$ / kWh. If the average is maintained throughout the month will be achieved approximately 7.2 kWh per month for each plate installed 50W. Considering the maximum charging of the inverter, which are eight plates is 57.6 kWh per month.

This value generated by eight plates 50W, means an economy in R\$ 38.02 per month for the consumer.

Therefore, each system with eight plates Kyocera 50W and 400W inverter GreenEnergy costs an average of R\$4,600.00. Following this reasoning, in 132 months or 11 years, the savings would pay the amount originally spent. Considering that the life of the plates is 30 years, the results are acceptable.

## 7. CONCLUSION

Based on this project remote monitoring it is possible to glimpse many other alternatives for use of the system by modifying and adapting specific points to the desired need.

In this way, it was possible to view part of a worldwide trend that is M2M (Machine to Machine), ie establish communication Machine to machine without human interference, and the solution that makes it possible multiple mobile machines and equipment be monitored remotely.

By means of M2M, it is possible that all the information collected by the monitoring modules are transmitted through a data network, be it wi-fi, ethernet, RF, Zigbee, GPRS, 3G, LTE, PLC and etc..

Analyzing the possibilities of using of using M2M opens up an enormous range. M2M applications involve different fields, such as fleet management (public safety, public transportation, taxis, delivery vehicles); utilities (SmartMeters - electricity meters, gas, water, and Telemetry - telemetry sensors and controllers,



navigation systems, vehicle maintenance, passenger safety and anti-theft systems), electronics (cameras and cameras, video games, ebook readers ) and others such as monitoring patients requiring constant monitoring, ATMs and self-service machines (credit card).

Thus, developing a project using newly discovered resources and on the rise causes the project to be very gratifying. It is estimated that the M2M market in Brazil should have a rate higher than the rest of the telecommunications market growth, averaging approximately 3.7% of the subscription market in 2016.

The possibility of developing new grouped the generation of clean energy technologies and add generation connected directly to the electrical grid, something that is also innovative because until a few years ago there was not the technology viable Grid Tie Inverter for minigeneration and microgeneration.

Therefore it is very satisfying to develop a project that contributes to sustainability, something the modern world will need to enhance with intense speed so that future generations can live in a nice planet as we live today.

There is a need of investment in rural residences which are not completely isolated and without opportunities for growth so that people could know a new world and approach the ones who live in large urban centers.

## REFERENCES

- ANEEL (National Electric Energy Agency). Resolution 482. Available in <[www.aneel.gov.br/cedoc/ren2012482.pdf](http://www.aneel.gov.br/cedoc/ren2012482.pdf)> accessed 01.nov.2012.
- Arduino. Available in <<http://www.arduino.cc/>> accessed 07.set.2012
- Banzi, M., "Getting Started with Arduino" book, Vol, No 1., December/2011, NovaTec.
- BRAZIL. Government Information. available in <<http://www.brasil.gov.br/noticias/arquivos/2012/07/03/energia-solar-ja-e-economicamente-viavel-para-15-dos-lares-brasileiros-diz-epe>> Accessed 22.out.2012
- BRAZIL, Solar - Photovoltaic Energy. Available in <<http://solarbrasil.com.br>> accessed 02.nov.2012.
- CRESESB (Reference Centre for Solar Energy and Wind Sérgio de Brito Saved). Studies of Solar Energy. Available in <<http://www.cresesb.cepel.br>> accessed 01.nov.2012
- Elster. Measurement systems. Available in <[http://energia.elster.com.br/pt/eletronicos\\_monofasicos.html](http://energia.elster.com.br/pt/eletronicos_monofasicos.html)> accessed 01.nov.2012.
- Energy, Solar - Photovoltaic Energy. Available in <<http://www.solarenergy.com.br>> accessed 02.nov.2012.
- FirstSolar. Solar Panels. available in <<http://www.firstsolar.com/Projects/Projects/Projects-Under-Development/Agua-Caliente-Solar-Project/Overview>> Accessed 22.nov.2012
- Iteadstudio. GSM Shield. Available in <<http://blog.iteadstudio.com/tag/shield/>> accessed 09.set.2012
- FSI. TCP / IP Architecture. Available in <<http://fsi-ufam.blogspot.com.br/2009/11/modelo-osi.html/>> accessed 21.nov.2012
- InfoWester. GSM network. Available in <<http://www.infowester.com/2g.php>> accessed 02.nov.2012
- Junior, Pedro Adolfo de Souza. Managed Access Control System Via GPRS. 2011. 65f. Completion of course work (undergraduate) - Department of Electrical Engineering, Federal University of Paraná. Available in <<http://www.eletrica.ufpr.br/ufpr2/tccs/176.pdf>> accessed 02.out.2012.
- Leitão, José Miguel, "Solar Energy: Bet or Necessity," E-topia: Electronic Journal of Utopian Studies, 11 (2010)..
- Meterspec. Elster A102C manual. Available at <<http://www.meterspec.com/143.pdf>> Accessed 20.nov.2012
- Mpptsolar. Solar Energy. Available in <<http://www.mpptsolar.com/pt/paineis-solares-em-serie.html>> accessed 02.nov.2012
- Oliveira, Victor Hugo Freitas. Development of a Remote Telemetry System. 2009. 58f. Completion of course work (undergraduate) - Department of Computer Engineering and Automation, Federal University of Rio Grande do Norte. Available in <<http://www.engcomp.ufrn.br/publicacoes/TCC-2009-1-1.pdf>> accessed 05.out.2012.
- Painelsolares. Solar Panels. Available in <<http://painelsolares.com/o-que-e-um-painel-solar/>> accessed 01.nov.2012
- Serrão, Marcons Antônio dos Santos. Sizing a Photovoltaic System For A summer house in Paraty Pouso da-Cajaíba. 2010. 89F. Project Completion of course (Undergraduate) - Department of Electrical Engineering, Polytechnic University of Rio de Janeiro. Available in <[http://monografias.poli.ufrj.br/monografias/mono\\_poli10000620.pdf](http://monografias.poli.ufrj.br/monografias/mono_poli10000620.pdf)> accessed 02.nov.2012.
- Sukhatme, SP, Nayak, JK 2008 Solar Energy - Solar Energy:. Principles of Thermal Collection and Storage.3rd Ed - Tata McGraw-Hill, 125-142.